

**Montage**

1. Trägerklammer ansetzen,  
Spannschraube handfest  
anziehen (Kontermutter  
falls nötig zurückdrehen).  
Spannschraube festziehen:  
1 bis max. 1½ Umdr.

**Nennlast**

Gruppe TCS 1: 5,0 kN

Diese Nennlasten gelten nur  
für neue TCS am unbeschä-  
digten Trägerflansch.

2. Kontermutter festziehen.

**Installation**

1. Position Beam Clamp.  
Hand-tighten clamping  
bolt (if necessary, unscrew  
the locking nut a  
bit). Tighten clamping bolt  
down with a spanner:  
1 up to 1½ revolutions.

**Max. working load  
(tension)**

Group TCS 1: 5.0 kN

The nominal loads indicated  
apply to new Beam Clamps  
fixed to undamaged beam  
flanges only.

2. Tighten locking nut using  
a spanner.

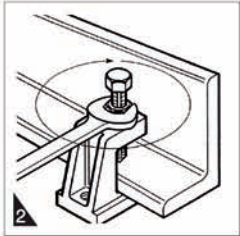

ohne Sicherungslasche  
without Safety Strap



mit Sicherungslasche  
with Safety Strap

**Montagebeispiele  
Mounting Examples**

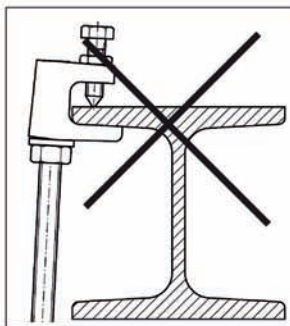
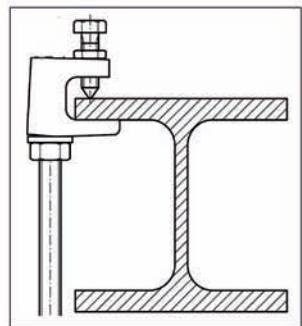

**Achtung!**

▶ Anordnung nur bei  
Pallelfanschträgern  
erlaubt.

**Caution!**

▶ This arrangement is  
permissible for parallel-  
flange beams only.

